

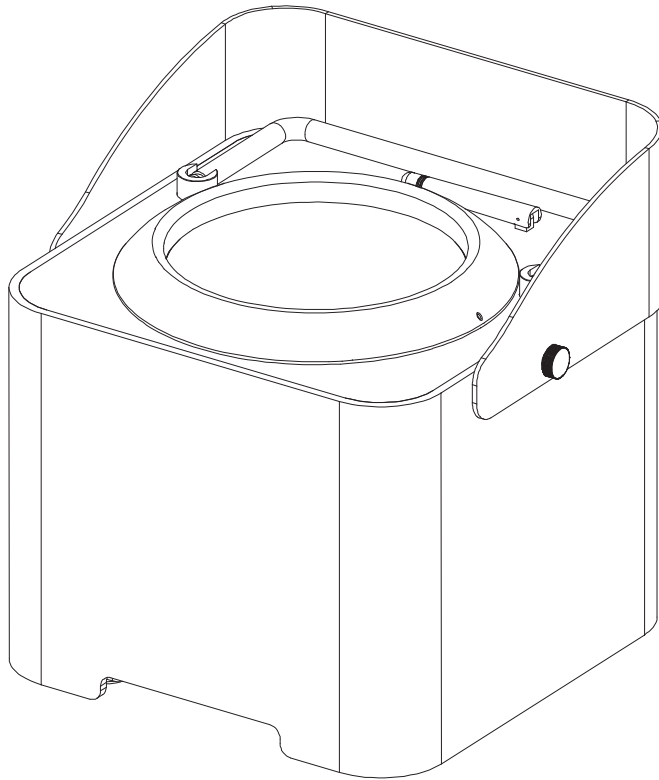

## WIFLY EXR DOTZ PAR



### ***User Instructions***

©2015 ADJ Products, LLC all rights reserved. Information, specifications, diagrams, images, and instructions herein are subject to change without notice. ADJ Products, LLC logo and identifying product names and numbers herein are trademarks of ADJ Products, LLC. Copyright protection claimed includes all forms and matters of copyrightable materials and information now allowed by statutory or judicial law or hereinafter granted. Product names used in this document may be trademarks or registered trademarks of their respective companies and are hereby acknowledged. All non-ADJ Products, LLC brands and product names are trademarks or registered trademarks of their respective companies.

**ADJ Products, LLC** and all affiliated companies hereby disclaim any and all liabilities for property, equipment, building, and electrical damages, injuries to any persons, and direct or indirect economic loss associated with the use or reliance of any information contained within this document, and/or as a result of the improper, unsafe, insufficient and negligent assembly, installation, rigging, and operation of this product.

Europe Energy Saving Notice

Energy Saving Matters (EuP 2009/125/EC)

Saving electric energy is a key to help protecting the environment. Please turn off all electrical products when they are not in use. To avoid power consumption in idle mode, disconnect all electrical equipment from power when not in use. Thank you!

## WiFly EXR Dotz Par

## Introduction

**Unpacking:** Thank you for purchasing the WiFly EXR Dotz Par by ADJ Products, LLC. Every WiFly EXR Dotz Par has been thoroughly tested and has been shipped in perfect operating condition. Carefully check the shipping carton for damage that may have occurred during shipping. If the carton appears to be damaged, carefully inspect your fixture for any damage and be sure all accessories necessary to operate the unit has arrived intact. In the case damage has been found or parts are missing, please contact our toll free customer support number for further instructions. Do not return this unit to your dealer without first contacting customer support.

**Introduction:** The WiFly EXR Dotz Par is part of ADJ's continuing pursuit for creating high quality affordable intelligent fixtures. The WiFly EXR Dotz Par is a high performance, battery powered, DMX intelligent, LED fixture, with built-in WiFly. The unit has 7 operating modes; static color mode, sound active mode, RGB dimmer mode, 3 color change mode, 7 color change mode, color fade mode, & DMX controlled. This unit can be used as a stand alone fixture, or in a Master/Slave configuration. This fixture is suitable for theaters, studios, retail stores, and other similar locations.

**Customer Support:** ADJ Products, LLC provides a toll free customer support line, to provide set up help and to answer any question should you encounter problems during your set up or initial operation. You may also visit us on the web at [www.adj.com](http://www.adj.com) for any comments or suggestions. Service Hours are Monday through Friday 8:00 a.m. to 4:30 p.m. Pacific Standard Time.

Voice: (800) 322-6337

Fax: (323) 582-2941

E-mail: [support@americandj.com](mailto:support@americandj.com)

To purchase parts online visit <http://parts.americandj.com>

**Warning!** To prevent or reduce the risk of electrical shock or fire, do not expose this unit to rain or moisture.

**Caution!** There are no user serviceable parts inside this unit. Do not attempt any repairs yourself, doing so will void your manufactures warranty. In the unlikely event your unit may require service please contact ADJ Products, LLC.

**PLEASE recycle the shipping carton when ever possible.**

ADJ Products, LLC - [www.adj.com](http://www.adj.com) - WiFly EXR Dotz Par User Manual Page 2

## WiFly EXR Dotz Par

## General Instructions

To optimize the performance of this product, please read these operating instructions carefully to familiarize yourself with the basic operations of this unit. These instructions contain important safety information regarding the use and maintenance of this unit. Please keep this manual with the unit, for future reference.

## WiFly EXR Dotz Par

## Features

- Battery Power
- Built-In WiFly
- RGB Color Mixing
- Strobing
- Electronic Dimming 0-100%
- Built in Microphone
- DMX-512 protocol
- Four DMX Modes: 3 Channel Mode, 4 Channel Mode, 5(d) Channel Mode, 5(s) Channel Mode, & 9 Channel Mode,
- 7 Operating Modes - Static Color Mode, Sound Active Mode, RGB Dimmer Mode, 3 Color Change, 7 Color Change, Color Fade Mode, & DMX Controlled
- 66 Degree Optional Lens
- Shield included helps to limit unwanted light exposure
- Manual Angle Adjustment
- Power Cord Daisy Chaining (See Page 24)

## WiFly EXR Dotz Par

## Warranty Registration

The WiFly EXR Dotz Par carries a 2 year (730 days) limited warranty. Please fill out the enclosed warranty card to validate your purchase and warranty. You may also register your product online at [www.americandj.com](http://www.americandj.com). All returned service items whether under warranty or not, must be freight pre-paid and accompany a return authorization (R.A.) number. If the unit is under warranty you must provide a copy of your proof of purchase invoice. Please contact ADJ Products, LLC customer support for a R.A. number.

- To reduce the risk of electrical shock or fire, do not expose this unit rain or moisture
- Do not spill water or other liquids into or on to your unit.
- Be sure that the local power outlet match that of the required voltage for your unit.
- Do not attempt to operate this unit if the power cord has been frayed or broken. Do not attempt to remove or break off the ground prong from the electrical cord. This prong is used to reduce the risk of electrical shock and fire in case of an internal short.
- Disconnect from main power before making any type of connection.
- Do not remove the cover under any conditions. There are no user serviceable parts inside.
- Never operate this unit when it's cover is removed.
- Never plug this unit in to a dimmer pack
- Always be sure to mount this unit in an area that will allow proper ventilation. Allow about 6" (15cm) between this device and a wall.
- Do not attempt to operate this unit, if it becomes damaged.
- This unit is intended for indoor use only, use of this product outdoors voids all warranties.
- During long periods of non-use, disconnect the unit's main power.
- Always mount this unit in safe and stable matter.
- Power-supply cords should be routed so that they are not likely to be walked on or pinched by items placed upon or against them, paying particular attention to the point they exit from the unit.
- Cleaning -The fixture should be cleaned only as recommended by the manufacturer. See page 24 for cleaning details.
- Heat -The appliance should be situated away from heat sources such as radiators, heat registers, stoves, or other appliances (including amplifiers) that produce heat.
- The fixture should be serviced by qualified service personnel when:
  - A. The power-supply cord or the plug has been damaged.
  - B. Objects have fallen, or liquid has been spilled into the appliance.
  - C. The appliance has been exposed to rain or water.
  - D. The appliance does not appear to operate normally or exhibits a marked change in performance.

## 1. Handling of Batteries

### 1.1 Do Not Short Circuit the Battery

Try to never short circuit the battery. It generates a very high current which could cause the battery to overheat which may result in electrolyte gel leakage, harmful fumes, or explosion. The LIR tabs may easily short-circuit by placing them on conductive surface. A short circuit may lead to heat build up and damage of the battery. An appropriate circuitry with PCM is employed to protect accidental short circuit of the battery pack.

### 1.2 Mechanical shock

Dropping the unit, impact hit, bending, etc. may cause failure or shortend life of the LIR battery.

## 3. Other

### 3.1 Battery connection

- 1). Direct soldering of wire leads or devices to the battery is strictly prohibited.
- 2). Lead tabs with pre-soldered wiring shall be spot welded to the batteries. Direct soldering may cause damage of components, such as separator and insulator, by heat build up.

### 3.2 Prevention of short circuit within a battery pack

There is enough insulation layers between wiring and the batteries to provide extra safety protection. The battery pack is constructed in a way that no short circuit will occur which may cause smoke or fire.

### 3.3 Do No Disassemble the Batteries

- 1). Never disassemble the batteries. Doing this may cause a internal short circuit in the battery, which may lead to harmful fumes, fire, explosion, or other problems.
- 2). Electrolyte Gel is harmful  
Electrolyte Gel should not leak from the LIR battery. Should the electrolyte gel come into contact with the skin or eyes, flush the

area of contact immediately with fresh water and seek medical attention immediately.

### **3.4 Do Not Expose the Battery to Heat or Fire**

Never incinerate or dispose of the batteries in fire. This may cause an explosion, which would be very dangerous.

### **3.5 Do Not Expose the Battery to water or liquids**

Never soak/drop the batteries in liquids such as water, seawater, drinks such as soft drinks, juices, coffee or other.

### **3.6 Battery Replacement**

For battery replacement please contact American DJ customer support (800) 322-6337.

### **3.7 Do Not use a damaged Battery**

The battery could be damaged during shipping, caused by shock. Should the battery be found damaged, including damages to the plastic casing of the battery, deformation of the battery package, smelling of an electrolyte, or leakage of the electrolyte gel, or other, DO NOT use the battery. A battery with a odor of electrolyte or a gel leakage should be placed away from fire to avoid fire or explosion.

## **4. Battery Storage**

When storing the battery, it should be stored at room temperature, with a charge of at least 50%. We recommend that during long periods of storage that the battery be charged every 6 months. Doing this will prolong the life of the battery and will also make sure that the battery charge does not fall below the 30% mark.

## **5. Other Chemical Reaction**

Because batteries utilize a chemical reaction, battery performance will deteriorate over time even if stored for a long period of time without being used. In addition, if the various usage conditions such as charge, discharge, ambient temperature, etc. are not maintained within the specified ranges, the

life expectancy of the battery maybe shortened or the device in which the battery is used may be damaged by electrolyte gel leakage. If the batteries cannot maintain a charge for long periods of time, even when they are charged correctly, this may indicate it is time to change the battery.

## **6. Battery Disposal**

Please dispose of battery according to local regulations.

**Power Supply:** The ADJ WiFly EXR Dotz Par contains a automatic voltage switch, which will auto sense the voltage when it is plugged into a power source. With this switch there is no need to worry about the correct power voltage, this unit can be plugged in anywhere.

**DMX-512:** DMX is short for Digital Multiplex. This is a universal protocol used as a form of communication between intelligent fixtures and controllers. A DMX controller sends DMX data instructions from the controller to the fixture. DMX data is sent as serial data that travels from fixture to fixture via the DATA “IN” and DATA “OUT” XLR terminals located on all DMX fixtures (most controllers only have a DATA “OUT” terminal).

**DMX Linking:** DMX is a language allowing all makes and models of different manufactures to be linked together and operate from a single controller, as long as all fixtures and the controller are DMX compliant. To ensure proper DMX data transmission, when using several DMX fixtures try to use the shortest cable path possible. The order in which fixtures are connected in a DMX line does not influence the DMX addressing. For example; a fixture assigned a DMX address of 1 may be placed anywhere in a DMX line, at the beginning, at the end, or anywhere in the middle. When a fixture is assigned a DMX address of 1, the DMX controller knows to send DATA assigned to address 1 to that unit, no matter where it is located in the DMX chain.

**Data Cable (DMX Cable) Requirements (For DMX Operation):**

The WiFly EXR Dotz Par can be controlled via DMX-512 protocol. The WiFly EXR Dotz Par has 4 DMX Channel Modes. The DMX address is set on the rear panel of the WiFly EXR Dotz Par. Your unit and your DMX controller require a approved DMX-512 110 Ohm Data cable for data input and data output (Figure 1). We recommend Accu-Cable DMX cables. If you are making your own cables, be sure to use standard 110-120 Ohm shielded cable (This cable may be purchased at almost all professional sound and lighting stores). Your cables should be made with a male and female XLR connector on either end of the cable. Also remember that DMX cable must be daisy chained and cannot be split.



Figure 1

**Notice:** Be sure to follow figures two and three when making your own cables. Do not use the ground lug on the XLR connector. Do not connect the cable’s shield conductor to the ground lug or allow the shield conductor to come in contact with the XLR’s outer casing. Grounding the shield could cause a short circuit and erratic behavior.

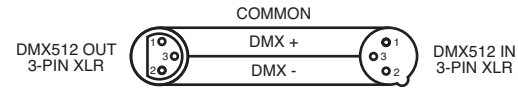

Figure 2

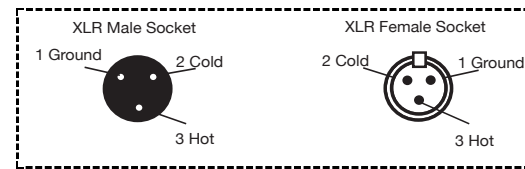

Figure 3

XLR Pin Configuration	
Pin 1 =	Ground
Pin 2 =	Data Compliment (negative)
Pin 3 =	Data True (positive)

**Special Note: Line Termination.** When longer runs of cable are used, you may need to use a terminator on the last unit to avoid erratic behavior. A terminator is a 90-120 ohm 1/4 watt resistor which is connected between pins 2 and 3 of a male XLR connector (DATA + and DATA -). This unit is inserted in the female XLR connector of the last unit in your daisy chain to terminate the line. Using a cable terminator (ADJ part number Z-DMX/T) will decrease the possibilities of erratic behavior.



Termination reduces signal errors and avoids signal transmission problems and interference. It is always advisable to connect a DMX terminal, (Resistance 120 Ohm 1/4 W) between PIN 2 (DMX-) and PIN 3 (DMX +) of the last fixture.

Figure 4

**5-Pin XLR DMX Connectors.** Some manufactures use 5-pin XLR connectors for DATA transmission in place of 3-pin. 5-pin XLR fixtures may be implemented in a 3-pin XLR DMX line. When inserting standard 5-pin XLR connectors in to a 3-pin line a cable adaptor must be used, these adaptors are readily available at most electric stores. The chart below details a proper cable conversion.

3-Pin XLR to 5-Pin XLR Conversion		
Conductor	3-Pin XLR Female (Out)	5-Pin XLR Male (In)
Ground/Shield	Pin 1	Pin 1
Data Compliment (- signal)	Pin 2	Pin 2
Data True (+ signal)	Pin 3	Pin 3
Not Used		Do Not Use
Not Used		Do Not Use

**Control Panel Lock:**

The control panel will lock itself after 30 seconds if nothing is pressed. To unlock the control panel, press the MODE button for 3 seconds.

**DMX Mode - Setting the DMX Address -**

1. Press the MODE button until “DMX MODE ADDR: XXX” is displayed. “XXX” represents the current displayed address. Press the ENTER button.
2. After pressing the ENTER button a flashing underscore should appear under the last number. Use the UP or DOWN buttons to change the DMX address.
3. Once you have found your desired DMX address, press the ENTER button again.

**DMX Channel Mode - This function will allow you to set your desired DMX channel mode -**

1. Press the MODE button until “CHANNEL CH: XXX” is displayed. “XXX” represents the current displayed DMX channel mode. Press the ENTER button.
2. After pressing the ENTER button a flashing underscore should appear. Use the UP or DOWN buttons to change the DMX channel mode.
3. Once you have found your desired DMX channel mode, press the ENTER button again.

**Dimmer Curve - This setting will let you select your desired dimmer curve. See the dimmer curve chart on page 23.**

1. Press the MODE button until “DimCurve” is displayed. Underneath “DimCurve” is the current dimming curve setting.
2. Press the ENTER button and a flashing underscore should

appear under the first letter of the current displayed dimmer curve.

3. Use the UP or DOWN buttons to change the dimmer curve setting.
4. Once you have found your desired dimming curve, press the ENTER button again.

**Built-In Programs - Select 1 of 4 programs. RGB Dimmer Mode, 7 Color Change, 3 Color Change 3, or Color Fade.**

1. Press the MODE button until either “1. MANUAL”, “2. CHANGE”, “3. CHANG3”, or “4. FADE” is displayed.
2. Press the ENTER button and a flashing underscore will appear under the first number. Use the UP and DOWN buttons to scroll through the 4 different programs. **Note: For “1. Manual” instructions see RGB Dimmer Mode.**
3. Both Color Change programs and the Color Fade program have adjustable changing and fading speeds. Once you have found your desired program, press ENTER.
4. The flashing underscore will now appear under the program speed adjustment. Use the UP and DOWN buttons to adjust the program speed. Press ENTER once you find your desired speed.
5. The flashing underscore will now appear under the strobe speed adjustment. Use the UP and DOWN buttons to adjust the strobe speed or completely turn it off. The “00” setting turns the strobe off, “01” is the slowest strobe rate, and “99” is the fastest strobe rate. Press ENTER once you find your desired strobe setting.

**RGB Dimmer Mode - Select your desired color to remain static or adjust the RGB colors to create your desired color.**

1. Follow instructions 1-2 under Built-In Programs.
2. Press the UP or DOWN buttons so that “1. Manual” is displayed, and press ENTER.
3. A flashing underscore will appear underneath the first color adjustment. Use the UP and DOWN buttons to adjust the color intensity to your liking. Press ENTER to set the color and move to the next color adjustment.
4. Continue to adjust the colors until you find your desired setting. Press the ENTER button until the underscore is located under “SXX”. “XX” represents the current strobe setting.
5. Use the UP and DOWN buttons to adjust the strobe speed or completely turn it off. The “00” setting turns the strobe off, “01” is the slowest strobe rate, and “99” is the fastest strobe rate. Press ENTER once you find your desired strobe setting.

**Color Macro - Select your desired color macro to remain static.**

1. Press the MODE button until “MACRO” is displayed. The current color macro setting is located underneath.
2. Press the ENTER button and the flashing underscore will appear under the color macro number. Use the UP and DOWN buttons to scroll through the 32 color macros until you find your desired color then press the ENTER button.

**NO DMX - This mode can be used as a precaution mode, that in case the DMX signal is lost, interrupted, or power is lost, the operating mode chosen in the setup is the running mode the fixture will go into when the DMX signal is lost. You can also set this as the operating mode you would like the**

**unit to return to when power is applied.**

1. Press the MODE button until “NO DMX” is displayed. The current No DMX setting will appear underneath.
2. Press the ENTER button and a flashing underscore will appear underneath the current No DMX setting. Use the UP or DOWN buttons to find an operating mode you would like the unit go into when the DMX signal is lost.

- Fade - If the DMX signal is lost or interrupted, the unit will automatically go into the fade program.
- Blackout - If the DMX signal is lost or interrupted, the unit will automatically go into stand by mode.
- Hold - If the DMX signal is lost or interrupted, the fixture will stay in the last DMX setting.

3. Press ENTER to confirm your desired set up.

**Sound Active Mode - In this mode the unit will run in sound active mode.**

1. Press the MODE button until “SOUND SENS: XX” is displayed. “XX” is the current sound sensitivity setting.
2. Press the ENTER button and a flashing underscore will appear under the sound sensitivity setting. Use the UP and DOWN buttons to adjust the sound sensitivity. “00” being the least sensitive, and “31” being the most.

**RF Active - This function will let you activate the RF remote control.**

1. Press the MODE button until “RFREMOTE” is displayed. Either “On” or “Off” will appear underneath.
2. Press the ENTER button and a flashing underscore will appear under the setting. Use the UP or DOWN buttons to activate (On) or deactivate (Off) the remote control.

**Slave Mode - This will let you set your unit as a slave in a master/slave configuration.**

1. Press the MODE button until “SLAVE MODE” is displayed. Your unit will now follow the Master.

**Wireless Channel - This function will let you set the wireless channel.**

1. Press the MODE button until “Wireless CH: XX” is displayed. “XX” represents the current channel setting.
2. Press the ENTER button and a flashing underscore will appear under the channel setting. Use the UP or DOWN buttons to find your desired wireless channel. Press ENTER to set the channel.

**Battery Ind. - This function will let you switch battery life indicators on/off.**

1. Press the MODE button until “Battery Ind.” is displayed.
2. Press the ENTER button and a flashing underscore will appear under the current setting. Use the UP or DOWN buttons to find you desired and setting and press ENTER.

**Universal DMX Control:** This function allows you to use a universal DMX-512 controller to control the chases and patterns, dimmer and strobe. A DMX controller allows you to create unique programs tailored to your individual needs. The WiFly EXR Dotz Par has 5 DMX channel modes; a 3 Channel Mode, 4 Channel Mode, two 5 Channel Modes, & 9 Channel Mode. See pages 18-21 for the DMX channel modes and traits.

1. This function will allow you to control each individual fixture’s traits with a standard DMX 512 controller.
2. To run your fixture in DMX mode, follow directions on page 10 to set your DMX address and DMX Channel mode.
3. Plug in the fixture via the XLR connections to any standard DMX controller.
4. For longer cable runs (more than a 100 feet) use a terminator on the last fixture.

With this feature you are able to control the unit with DMX without the need of XLR cables. Your DMX controller must be connected to a ADJ WiFly EXR Transceiver to use this function. You are able to communicate up to 1,200 feet (open line of sight) when using a ADJ WiFly EXR Battery Transceiver.

1. Follow the instructions on page 14 to set the Wireless channel. The address must match the address set on the WiFly Transceiver.
2. After you have set the WiFly address, follow the DMX instructions on page 7 to select your desired DMX Channel mode and set your DMX address.
4. Apply power to the ADJ WiFly EXR Battery Transceiver. The fixture must be set up first before you apply power to WiFly Transceiver.
5. If everything is set up properly and the fixture is receiving a Wireless signal, Wireless status LED next to LED screen will glow green.



**Master-Slave Operation:** This function will allow you to link up to 16 units together and operate without a controller. In a Master-Slave set up one unit will act as the controlling unit and the others will react to the controlling units programs. Any unit can act as a Master or as a Slave. You can also use WiFly in Master-Slave configuration, so that you do not need the use of XLR cables.

1. Using approved DMX data cables, daisy chain your units together via the XLR connector on the rear of the units. Remember the Male XLR connector is the input and the Female XLR connector is the output. The first unit in the chain (master) will use the female XLR connector only - The last unit in the chain will use the male XLR connector only. For longer cable runs we suggest a terminator at the last fixture.
2. On the Master unit, set your desired operating mode.
3. On the slave units press the MODE button until "Slave Mode" is displayed.

**WiFly Set Up:** This feature will let you link units to run in a master-slave mode without the use of XLR cables.

1. Follow the instructions on page 14 to set the wireless address. The addresses on each fixture must be the same.
2. After you have set the wireless addresses, select your "Master" unit and set your desired operating mode.
3. On the slave units press the MODE button until "Slave Mode" is displayed.
4. If everything is set up correctly, the "Slave" units will start following the "Master" unit.

The WiFly EXR Dotz Par RF remote has many different functions and allows you to control your WiFly EXR Dotz Par from long distance. The remote can control your system up to 25 meters. To use the remote you must first activate the fixtures receiver, to activate the receiver please see the instructions on page 13.

**BLACKOUT** - Pressing this button will blackout the fixture.

**FADE** - Press this button to activate fade speed adjustment and use the "+" and "-" buttons to adjust the fade speed.

**COLOR** - This button will activate the color macro mode. Use the "+" and "-" buttons to scroll through the colors and find your desired color.

**PROGRAMS** - This button will activate the built-in programs mode. Use the "+" and "-" buttons to scroll through the 4 programs.

**SOUND ACTIVE** - This button activates sound active mode.

**AUTO RUN** - Press this button to activate color change speed adjustment and use the "+" and "-" buttons to adjust the change speed.

### ***Battery On/Off Switch:***

The Battery on/off switch is located underneath the unit next to I.E.C. power input.

### ***Battery Status:***

The LED indicators located on the control panel will allow you to see the status of the battery life. If all four LEDs are lit you are at 100%. 3 LEDs is 75%, 2 LEDs is 50%, and 1 LED is 25%.

***Please do not let the battery fully die, this severely shortens the life of the battery.***

***Battery Recharge:*** To recharge the battery, switch off the battery on/off switch. Plug the provided I.E.C. power cord into a power outlet. When the charge indicator LED is red, the unit is charging. When the charge indicator LED turns green, it means that the battery is at full charge.

WiFly EXR Dotz Par		3 Channel Mode
Channel	Value	Function
1	0 - 255	RED 0% - 100%
2	0 - 255	GREEN 0% - 100%
3	0 - 255	BLUE 0% - 100%

WiFly EXR Dotz Par		4 Channel Mode
Channel	Value	Function
1	0 - 255	RED 0% - 100%
2	0 - 255	GREEN 0% - 100%
3	0 - 255	BLUE 0% - 100%
4	0 - 255	MASTER DIMMER 0% - 100%

WiFly EXR Dotz Par		5(d) Channel Mode
Channel	Value	Function
1	0 - 255	RED 0% - 100%
2	0 - 255	GREEN 0% - 100%
3	0 - 255	BLUE 0% - 100%
4	0 - 255	MASTER DIMMER 0% - 100%
5	0 - 20 21 - 40 41 - 60 61 - 80 81 - 100 101 - 255	DIMMER CURVES STANDARD STAGE TV ARCHITECTURAL THEATRE DEFAULT TO UNIT SETTING

WiFly EXR Dotz Par		5(s) Channel Mode
Channel	Value	Function
1	0 - 255	RED 0% - 100%
2	0 - 255	GREEN 0% - 100%
3	0 - 255	BLUE 0% - 100%
4	0 - 31 32 - 95 96 - 127 128 - 159 160 - 191 192 - 223 224 - 255	STROBING LED ON STROBING SLOW - FAST LED ON PULSE STROBE LED ON RANDOM STROBE LED ON
5	0 - 255	MASTER DIMMER 0% - 100%

WiFly EXR Dotz Par		9 Channel Mode
Channel	Value	Function
1	0 - 255	RED 0% - 100%
2	0 - 255	GREEN 0% - 100%
3	0 - 255	BLUE 0% - 100%
4	0 - 255	MASTER DIMMER 0% - 100%
5	0 - 255	COLOR MACROS See page 21 for color macro chart
6	0 1 - 20 21 - 40 41 - 60 61 - 80 81 - 100 101 - 120 121 - 140 141 - 255	PROGRAMS OFF COLOR FADE/CHANGE 7 COLOR CHANGE 7 COLOR FADE 3 COLOR CHANGE 3 COLOR FADE SOUND ACTIVE COLOR FADE SOUND ACTIVE COLOR CHANGE NOTHING
7	0 - 255 0 - 255	PROGRAM SPEED/SOUND SENSITIVE PROGRAM SPEED SLOW - FAST LEAST SENSITIVE - MOST SENSITIVE
8	0 - 31 32 - 95 96 - 127 128 - 159 160 - 191 192 - 223 224 - 255	STROBING LED ON STROBING SLOW - FAST LED ON PULSE STROBE LED ON RANDOM STROBE LED ON
9	0 - 41 42 - 84 85 - 127 128 - 170 171 - 213 214 - 255	DIMMER CURVES STANDARD STAGE TV ARCHITECTURAL THEATRE DEFAULT TO UNIT CURVE SETTING

WiFly EXR Dotz Par		9 Channel Mode
Note: 9 Channel Mode:		
<ul style="list-style-type: none"> <li>• When Channel 5 is being used Channels 1 - 3 will not function.</li> <li>• When Channel 6 is between the values of 1-100, Channel 7 will control the program speed.</li> <li>• When Channel 6 is between the values of 101-140, Channel 7 will control the sound sensitive.</li> </ul>		
WiFly EXR Dotz Par		Color Macro Chart
DMX values	C1-32	Colors
1-7	1	R=255; G=206; B=143
8-15	2	R=254; G=177; B=153
16-23	3	R=254; G=192; B=138
24-31	4	R=254; G=165; B=98
32-39	5	R=254; G=121; B=0
40-47	6	R=176; G=17; B=0
48-55	7	R=96 ; G=0 ; B=11
56-63	8	R=234 ; G=139; B=171
64-71	9	R=224; G=5; B=97
72-79	10	R=175; G=77; B=173
80-87	11	R=119 ; G=130; B=199
88-95	12	R=147 ; G=164; B=212
96-103	13	R=88; G=2; B=163
104-111	14	R=0; G=38; B=86
112-119	15	R=0 ; G=142; B=208
120-127	16	R=52; G=148; B=209
128-135	17	R=1 ; G=134 ; B=201
136-143	18	R=0; G=145; B=212
144-151	19	R=0; G=121; B=192
152-159	20	R=0; G=129; B=184
160-167	21	R=0; G=83; B=115
168-175	22	R=0; G=97; B=166
176-183	23	R=1; G=100; B=167
184-191	24	R=0; G=40; B=86
192-199	25	R=209; G=219; B=182
200-207	26	R=42; G=165; B=85
208-215	27	R=0; G=46; B=35
216-223	28	R=8; G=107; B=222
224-231	29	R=255; G=0; B=0
232-239	30	R=0; G=252; B=0
240-247	31	R=0; G=0; B=255
248-255	32	R=255; G=255; B=255

## WiFly EXR Dotz Par

## Photometrics

Lens Off

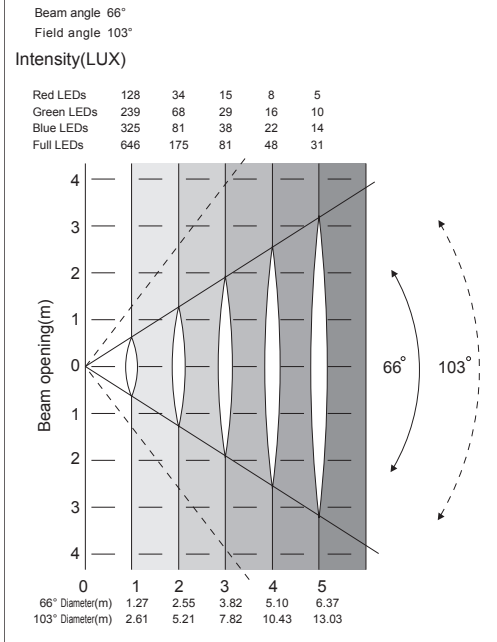

Lens On

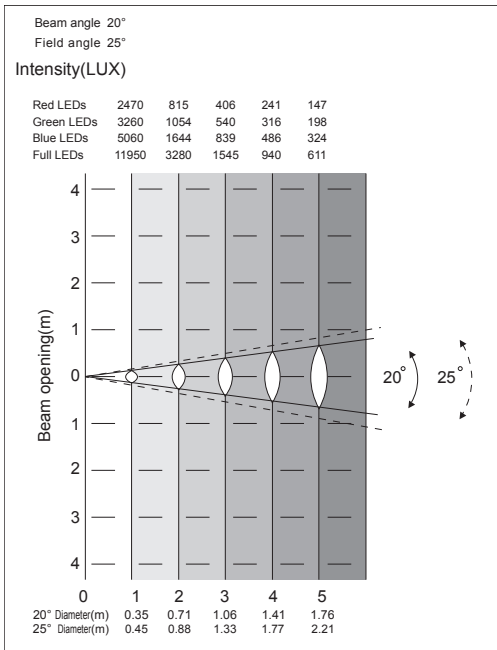

## WiFly EXR Dotz Par

## Removable Lens

The WiFly EXR Dotz Par comes with 66 degree lens already attached. The lens is held in place by two magnets on either side. To remove the lens simply rotate the lens so that lens comes off its magnets and lift to remove. The other way to remove it is to grab the edges of the lens and lift up. When the lens is removed the fixture will have a 20 degree beam angle.

## WiFly EXR Dotz Par

## Shield Attachment

The included shield is block unwanted light exposure when the fixture is used for uplighting. To attach the shield locate the thumb screws on each side of the unit. Remove the thumb screws, place the shield on the unit lining up the screw holes on the shield with screw holes on the unit. Reinsert the thumb screws and tighten.

## WiFly EXR Dotz Par

## Adjustable Sitting Angle

The standing angle of the unit can be manually adjusted by turning the knob on the front panel counter clockwise. Turning this knob will allow the bottom front part of the unit to lower so that the unit can sit at a desired angle. Turn the knob clockwise to lock the position.

## WiFly EXR Dotz Par

## Dimmer Curve Chart

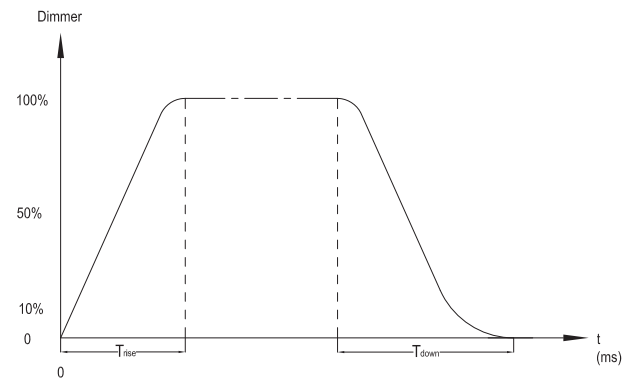

Ramp Effect	0 $\frac{1}{255}$ OS (Fade Time)		0 $\frac{1}{255}$ 1S (Fade Time)	
	T <sub>rise</sub> (ms)	T <sub>down</sub> (ms)	T <sub>rise</sub> (ms)	T <sub>down</sub> (ms)
Standard	0	0	0	0
Stage	780	1100	1540	1660
TV	1180	1520	1860	1940
Architectural	1380	1730	2040	2120
Theatre	1580	1940	2230	2280

## WiFly EXR Dotz Par

## Power Cord Daisy Chaining

***With this feature you can connect the fixtures to one another using the IEC input and output sockets. The quantity that can be connected is 9 fixtures maximum for 120V, and 19 fixtures maximum for 230V. After the maximum fixtures has been reached you will need to use a new power outlet. They must be the same fixtures. DO NOT mix fixtures.***

## WiFly EXR Dotz Par

## Fuse Replacement

Locate and remove the unit's power cord. Once the cord has been removed locate the fuse holder located inside the power socket. Insert a flat-head screw driver into the power socket and gently pry out the fuse holder. Remove the bad fuse and replace with a new one. The fuse holder has a built-in socket for a spare fuse be sure not to confuse the spare fuse with active fuse.

## WiFly EXR Dotz Par

## Cleaning

Due to fog residue, smoke, and dust cleaning the internal and external optical lenses must be carried out periodically to optimize light output.

1. Use a soft cloth to wipe down the outside casing.

Cleaning frequency depends on the environment in which the fixture operates (i.e. smoke, fog residue, dust, dew).

## WiFly EXR Dotz Par

## Troubleshooting

Listed below are a few common problems the user may encounter, with solutions.

### ***Unit not responding to DMX:***

1. Check that the DMX cables are connected properly and are wired correctly (pin 3 is "hot"; on some other DMX devices pin 2 may be 'hot'). Also, check that all cables are connected to the right connectors; it does matter which way the inputs and outputs are connected.

### ***Unit does not respond to sound:***

1. Quiet or high pitched sounds will not activate the unit.

*If problems are not resolved; Contact ADJ Products, LLC for service.*  
1-800-322-6337

## WiFly EXR Dotz Par

## Warranty

### MANUFACTURER'S LIMITED WARRANTY

- A. ADJ Products, LLC hereby warrants, to the original purchaser, ADJ Products, LLC products to be free of manufacturing defects in material and workmanship for a prescribed period from the date of purchase (see specific warranty period on reverse). This warranty shall be valid only if the product is purchased within the United States of America, including possessions and territories. It is the owner's responsibility to establish the date and place of purchase by acceptable evidence, at the time service is sought.
- B. **For warranty service you must obtain a Return Authorization number (RA#) before sending back the product—please contact ADJ Products, LLC Service Department at 800-322-6337.** Send the product only to the ADJ Products, LLC factory. All shipping charges must be pre-paid. If the requested repairs or service (including parts replacement) are within the terms of this warranty, ADJ Products, LLC will pay return shipping charges only to a designated point within the United States. If the entire instrument is sent, it must be shipped in its original package. No accessories should be shipped with the product. If any accessories are shipped with the product, ADJ Products, LLC shall have no liability whatsoever for loss of or damage to any such accessories, nor for the safe return thereof.
- C. This warranty is void if the serial number has been altered or removed; if the product is modified in any manner which ADJ Products, LLC concludes, after inspection, affects the reliability of the product; if the product has been repaired or serviced by anyone other than the ADJ Products, LLC factory unless prior written authorization was issued to purchaser by ADJ Products, LLC; if the product is damaged because not properly maintained as set forth in the instruction manual.
- D. This is not a service contract, and this warranty does not include maintenance, cleaning or periodic check up. During the period specified above, ADJ Products, LLC will replace defective parts at its expense with new or refurbished parts, and will absorb all expenses for warranty service and repair labor by reason of defects in material or workmanship. The sole responsibility of ADJ Products, LLC under this warranty shall be limited to the repair of the product, or replacement thereof, including parts, at the sole discretion of ADJ Products, LLC. All products covered by this warranty were manufactured after August 15, 2012, and bear indentifying marks to that effect.
- E. ADJ Products, LLC reserves the right to make changes in design and/or improvements upon its products without any obligation to include these changes in any products theretofore manufactured.

No warranty, whether expressed or implied, is given or made with respect to any accessory supplied with products described above. Except to the extent prohibited by applicable law, all implied warranties made by ADJ Products, LLC in connection with this product, including warranties of merchantability or fitness, are limited in duration to the warranty period set forth above. And no warranties, whether expressed or implied, including warranties of merchantability or fitness, shall apply to this product after said period has expired. The consumer's and/or Dealer's sole remedy shall be such repair or replacement as is expressly provided above; and under no circumstances shall ADJ Products, LLC be liable for any loss or damage, direct or consequential, arising out of the use of, or inability to use, this product.

This warranty is the only written warranty applicable to ADJ Products, LLC Products and supersedes all prior warranties and written descriptions of warranty terms and conditions heretofore published.

### MANUFACTURER'S LIMITED WARRANTY PERIODS:

- **Lighting Products = 1-year (365 days) Limited Warranty** (Such as: Special Effect Lighting, Intelligent Lighting, UV lighting, Strobes, Fog Machines, Bubble Machines, Mirror Balls, Par Cans, Trussing, Lighting Stands etc. excluding LED and lamps)
- **Laser Products = 1 Year (365 Days) Limited Warranty** (excluding laser diodes which have a 6 month limited warranty)
- **L.E.D. Products = 2-year (730 days) Limited Warranty** (excluding motors, PCB boards, and power supplies, which have a 1-year (365 day Limited Warranty) batteries which have a 180 day limited warranty). Only the L.E.D.s carry a 2-year warranty (excluding StarTec Series which carries a 90 Day Limited Warranty)
- **ADJ DMX Controllers = 2 Year (730 Days) Limited Warranty** (excluding faders and tact switches)

**SPECIFICATIONS:**

Voltage:	100V~240V 50Hz/60Hz
LEDs:	1 x 36W COB TRI LED
Battery Charge Time:	4 Hours
Battery Life:	8 Hours Full On (With Full Charge)
Battery Lifetime:	Average Lifetime is 500 Charges
Power Draw:	38W
Beam Angle:	20 Degrees 66 Degrees (w/o Lens Cover)
Fuse:	2Amp
Power Cord Daisy Chain:	10 Fixtures Max. (120V) 18 Fixtures Max. (230V)
Weight:	12lbs./ 5.5 kgs.
Dimensions:	8.25" (L) x 7.75" (W) x 9.75" (H) 210 x 200 x 250mm
Colors:	RGB Color Mixing
DMX Channels:	5 DMX Modes: 3 Channel Mode, 4 Channel Mode, 5(d) Channel Mode, 5(s) Channel Mode, & 9 Channel Mode
Working Position:	Any safe working position
Warranty:	2 Year (730 days)

**Auto Sensing Voltage:** This fixture contains a automatic voltage switch, which will auto sense the voltage when it is plugged into the power source.

**Please Note:** Specifications and improvements in the design of this unit and this manual are subject to change without any prior written notice.

ADJ Products, LLC  
6122 S. Eastern Ave. Los Angeles, CA 90040 USA  
Tel: 323-582-2650 / Fax: 323-725-6100  
Web: [www.adj.com](http://www.adj.com) / E-mail: [info@americandj.com](mailto:info@americandj.com)

A.D.J. Supply Europe B.V.  
Junostraat 2  
6468 EW Kerkrade  
Netherlands

Follow Us On:



[facebook.com/americandj](https://facebook.com/americandj)  
[twitter.com/americandj](https://twitter.com/americandj)  
[youtube.com/adjlighting](https://youtube.com/adjlighting)

[service@adjgroup.eu](mailto:service@adjgroup.eu) / [www.adj.eu](http://www.adj.eu)  
Tel: +31 45 546 85 00 / Fax: +31 45 546 85 99